

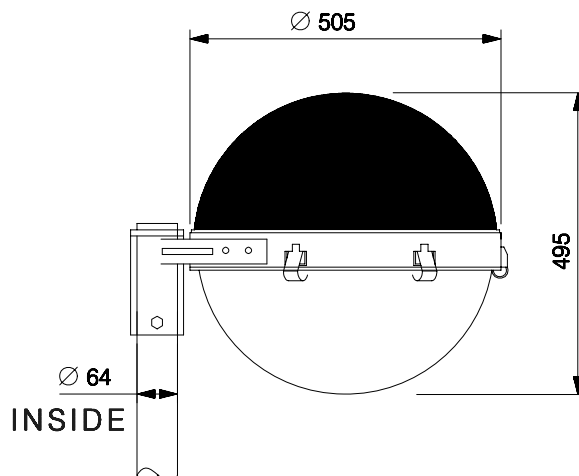

RENAISSANCE

BRSGL 150/250 SV/MH

Integral decorative roadway furniture with clear/opal acrylic for MH Lamp



NOMINAL DIMENSIONS IN mm Tolerance +/-5

**Applications**

- Parks and gardens
- Pathways
- Landscape lighting
- Pedestrian, etc

**Features**

- Fully vermin and weather proof
- Easy to install and maintain
- Degree of protection : IP 54
- Electrical safety – Class I

**Specifications**

- Black painted circular ring with top mounting arrangement
- Black painted Aluminium canopy is provided on top & clear acrylic cover fixed to the circular ring at bottom
- Electrochemically brightened, computer added designed pot optic aluminium reflector for tubular lamp
- Control gear for 150/250 SV/MH lamp, GES lamp holder prewired upto the terminal block
- Bottom entry mounting for 50 mm OD pipe bracket

**Electrical Data**

Cat. Ref.	Lamp Type & Wattage (W)	Nominal Voltage (V)	Mains Current In Amps. At 240 V	Capacitor Mfd	Power Factor
BRSGL 150 SV/MH	HPSV/MH 150	220/240	0.80	20	0.85
BRSGL 250 SV/MH	HPSV/MH 250	220/240	1.30	30	0.85

Data subject to variation due to change/improvement in the design, materials and processes.

 <b>BAJAJ LUMINAIRES</b> <i>Making the difference</i>	DRAWN	VDS	20-11-2007	FOR –
	CHECKED	KS		REV - 0 DATE-20-11-2007
	APPROVED	CRR		DRG. No
	DATA SHEET RELEASED ON DT-			RSGL 150SV 19"SM-001
<b>BAJAJ ELECTRICALS LIMITED</b> 15/17, SANT SAVTA MARG, REAY ROAD, MUMBAI-400 010.				* E-mail : <a href="mailto:luminaires@bajajelectricals.com">luminaires@bajajelectricals.com</a>